

LUNIS.
FROM RÖHM.

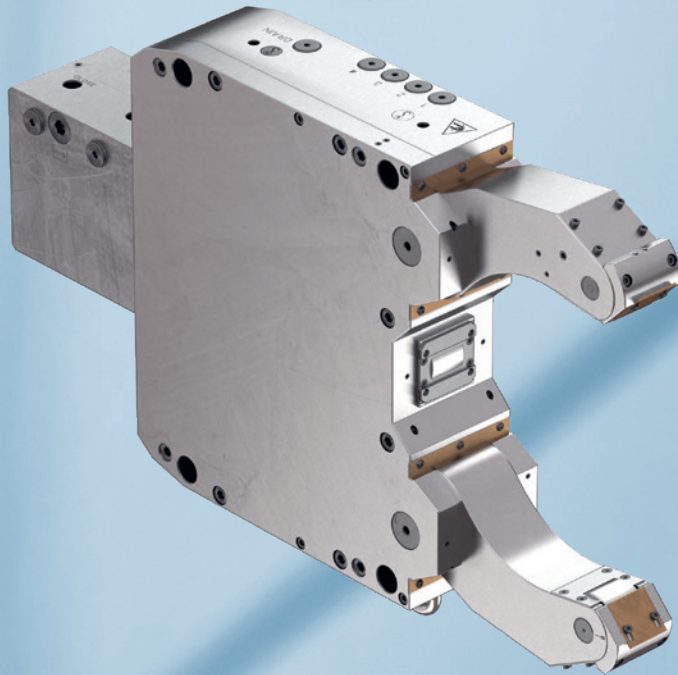

**A HELPING HAND
FOR YOUR
MACHINE TOOL**



MAX. DEVIATION OF 5 μ

The Lunis is a self-centering, hydraulically actuated steady rest. It is mainly used on CNC turning machines for supporting long, slim turned parts during machining. It enables concentricity and form tolerances of max. 5 μ m to be maintained.

Even in the basic version (from size 08-105), the Lunis is sealed as standard.

For tight installation spaces, there is the Lunis-B version with a side-mounted cylinder.

If required, compressed air can be used to prevent contamination from chips, coolant or debris. In the LUNIS-SC, coolant replaces compressed air for this function. Optional chip guards are available upon request to avoid scratching the surface of the workpiece.

The Lunis replaces the Röhms steady rests from the SLZN and SLZNB series. The name "Lunis" comes from Latin (lat: Luna = moon) and refers to the figure of the crescent-shaped clamping arms.

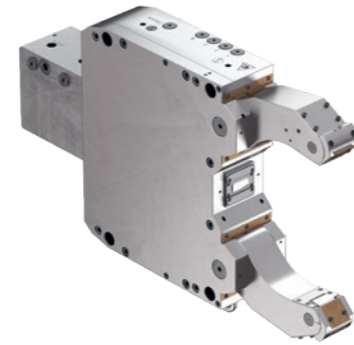

WHERE?

Automatically clamping, horizontal and vertical turning machines

FOR WHAT?

Support of long, slim turned parts for the highest accuracy up to 5 microns during turning

WHY?

- Modular system allows numerous combinations
- Sealed housing as standard!
- Standard connection for sealing air

HOW MUCH?

- Excellent price/performance ratio
- Low air consumption due to sealing

① Basic version from size 08-105

THE LUNIS IS PERFECTLY POISED

For supporting long, slim turned parts to provide the highest accuracy

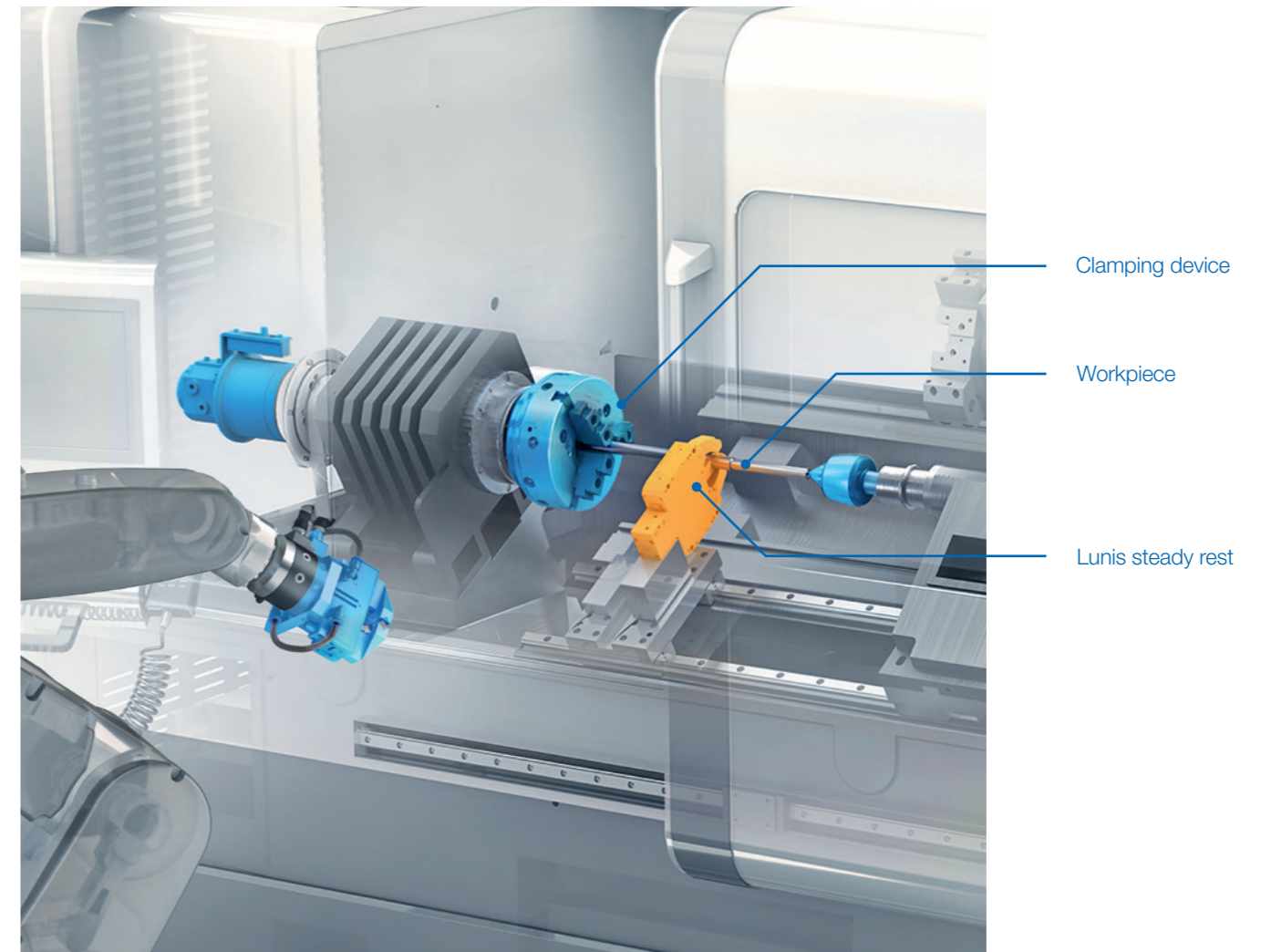

CLEAN ROUTINE, GREAT BREATHING TECHNIQUE

Features a sealing-air connection,
and sealed as standard

Sealing parts that move against each other is always a challenge for designers. Especially with a steady rest, because there are not only moving clamping arms here but also the tightest tolerances are required to guarantee high accuracies. The Lunis can therefore always be pressurized with sealing air. Overpressure inside the steady rest ensures that no particles or foreign bodies can penetrate. To keep air consumption as low as possible, all versions (from size 08-105) are sealed; this is easily recognizable by the designation Lunis-S (S=sealed).

To further minimize the sealing air, the air consumption is automatically reduced when the steady rest is fully open. In addition, the pressurized of the steady rest can be used to clean the center roller bearing.

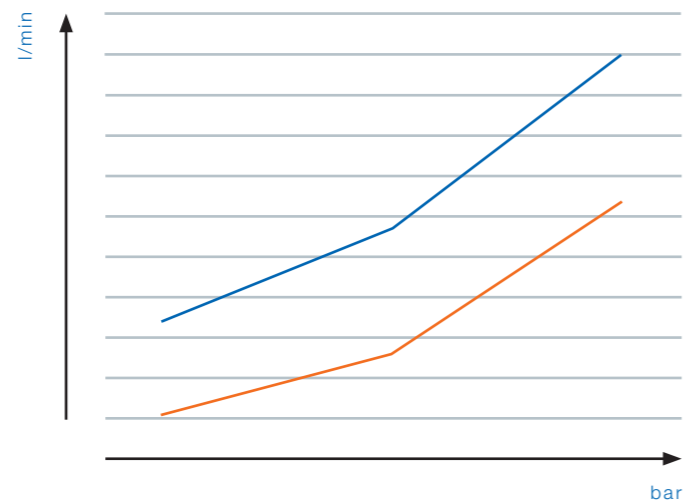
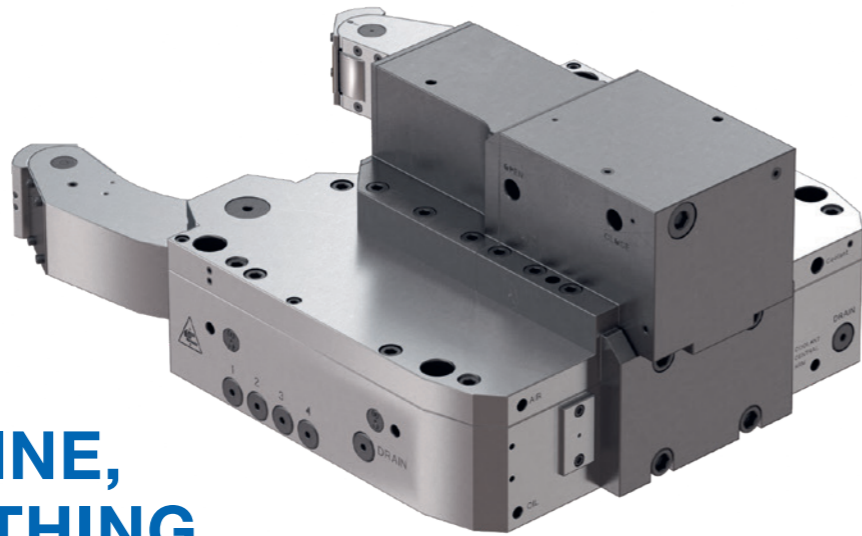

Lunis steady rests are sealed as standard, which saves expensive compressed air. Comparison: The air consumption [l/min] of a non-sealed steady rest (blue) and a sealed steady rest (orange), as a function of the pressure [bar].

WHEN CHALK WON'T HELP

Cylindrical or spherical rollers

To keep the friction of the rotating workpiece as low as possible during machining, the clamping force is applied at the end of the clamping arms via pressure rollers. The rollers have radial and axial roller bearings. For optimum contact with the workpiece, they are cylindrically shaped (RZ) and are manufactured with the highest concentricity precision.

For special clamping situations, the rollers are optionally available in a spherical design (RB). This shape prevents tilting when moving the steady rest. It can also be used to create slightly conical geometries.

Special versions, such as plastic rollers, for example, are available from us on request.



Optional eccentric fine adjustment, right in the Lunis SC (with cooling water pressurization, SC=sealed, coolant)

FOR THE PERFECT LINE

Option: Eccentric roller adjustment for fine adjustment of the concentricity without moving the steady rest body

The achievable precision when working with a steady rest depends to a large extent on its exact position. Here it is crucial that the clamping arms clamp precisely to the axis of rotation of the workpiece. Fine adjustment of the clamping direction towards the axis of rotation can be made via the optional roller adjustment. In doing so, the rotation axes of the rollers are slightly shifted and thus enable perfect alignment.

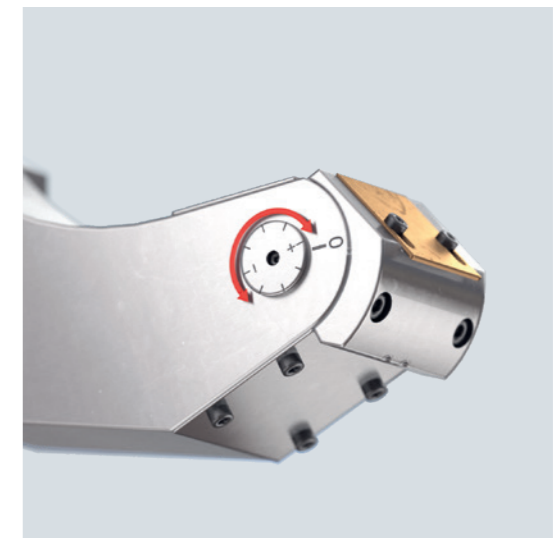

DISMOUNT TO THE SIDE OR REAR

Hydraulic cylinder in two designs

Installation space is precious. This also applies to the space in machine tools. That is why the Lunis is available in two variants. Mostly, Lunis steady rests are used with a hydraulic cylinder mounted on the back. The steady rest is then, slimmer and the useful travelling distance on the carriage is greater. Alternatively, there is the Lunis-B with a side-mounted cylinder. This makes the steady rest shorter toward the rear and particularly suitable for use in confined spaces at the rear.

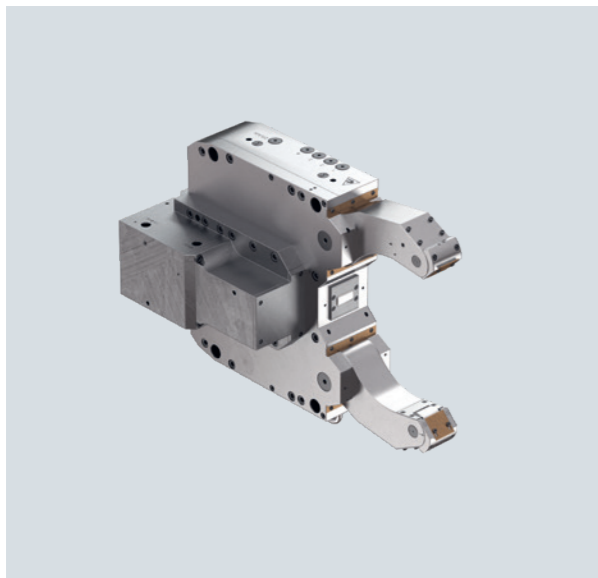

Lunis-B with side-mounted cylinder

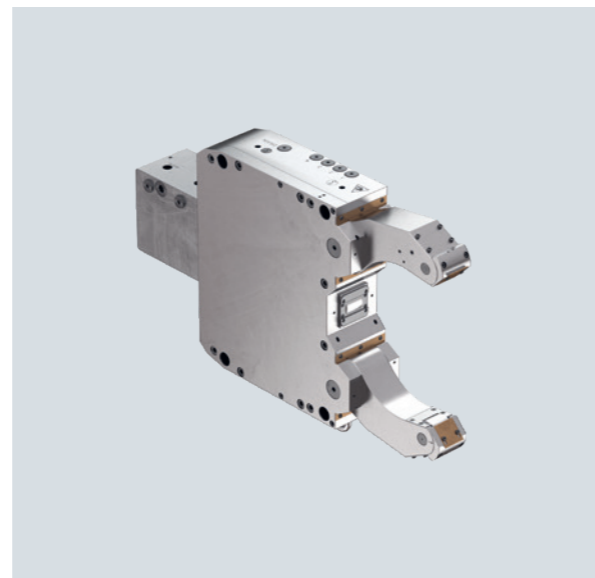

Lunis with rear-mounted cylinder

KEEP YOUR COOL

Optional coolant supply in the arms for cooling, flushing and cleaning of the rollers on the machining surface

For optimal cooling at the clamping points, the steady rests in the Lunis SC version can optionally be equipped with a coolant supply (SC = sealed and coolant). Coolant or air is fed through the arms of the steady rest directly to the clamping point. From size 30-250 onward, the coolant or air can also be fed through the center arm in addition to

the side arms (it has a separate connection, so the air or coolant can be controlled individually).

Our designers have asked themselves how flushing can be optimally applied to the workpiece. Modern shower heads were the inspiration for the design of the outlet plates. They ensure the widest possible, most uniform showering. Like a good shower head, they can be moved and adjusted to the diameter of the workpiece to be supported.

In addition to optimal coolant guidance, the outlet plates also serve as a chip guard and prevent chips from getting under the rollers, thus impairing the concentricity and surface quality.

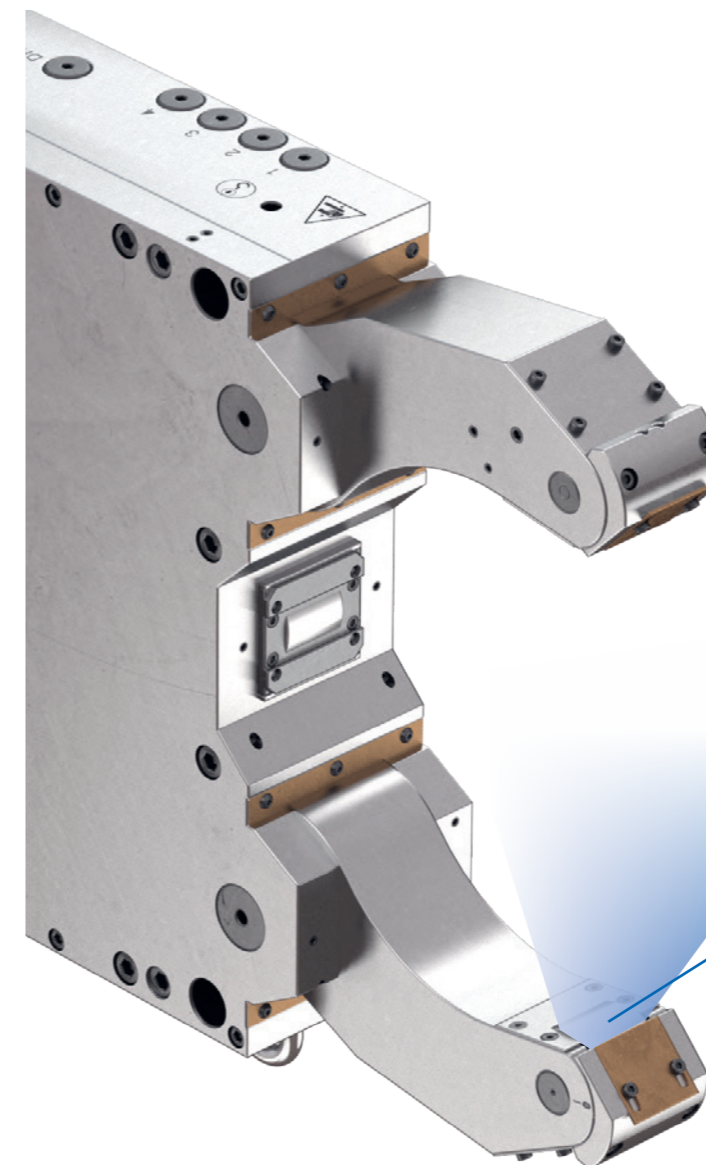

Lunis-SC with optional coolant supply

OPTIONS FOR STAYING FLEXIBLE

Standard: machine lubrication

Optional: manual

To lubricate the steady rests, they are—as a rule, and if available—connected to the central lubrication system of the machine. Only one connection is required for this. The metering units for the rollers are integrated into the steady rest body and ensure sufficient lubrication at time intervals (2-5 minutes, depending on the load, at 16-50 bar).

If automatic lubrication is not possible or not desired, upon request, an option for manual lubrication via a grease nipple or grease gun is available.

ALWAYS A TIGHT GRIP

Reliable clamping in the event of loss of pressure

All² versions of the Lunis steady rests have a pressure retaining valve integrated into the cylinder. In the event of a sudden pressure drop in the supply line, it ensures that the pressure in the cylinder is maintained, thereby preventing the steady rest from opening. This feature can also be omitted in the case of concurrent machining operations. In this case, an equivalent safety device must be installed instead.

MINIMIZE THE RISK OF INJURY

Optional chip guard prevents chips from being drawn in.

Rotating components on machine tools tend to draw in chips. Here, they end up between the roller and the workpiece. To prevent this, there is an optional chip guard (SS). It is positioned in front of the rollers in such a way that no chips can enter. The chip guards can be bolted in place to prevent damaging very sensitive surfaces.

If the steady rest is equipped with the optional coolant feed-through (SC), no additional chip guard is required. In this case, the outlet plate also acts as a chip guard to guide the coolant or air in a targeted manner.

Optional chip guard (SS)

On the Lunis SC variant, the chip guard is integrated: The outlet plate assumes the function.

TAKE TOP POSITION

Optional position and position indicator for determining the clamping arm position

To check on the machine side whether the steady rest is in the fully open position, an optional proximity switch is available.

If the exact position of the clamping arms is to be measured on the machine side, the Lunis³ can optionally be equipped with the inductive position indicator F90.

Optional proximity switch for detecting the open position

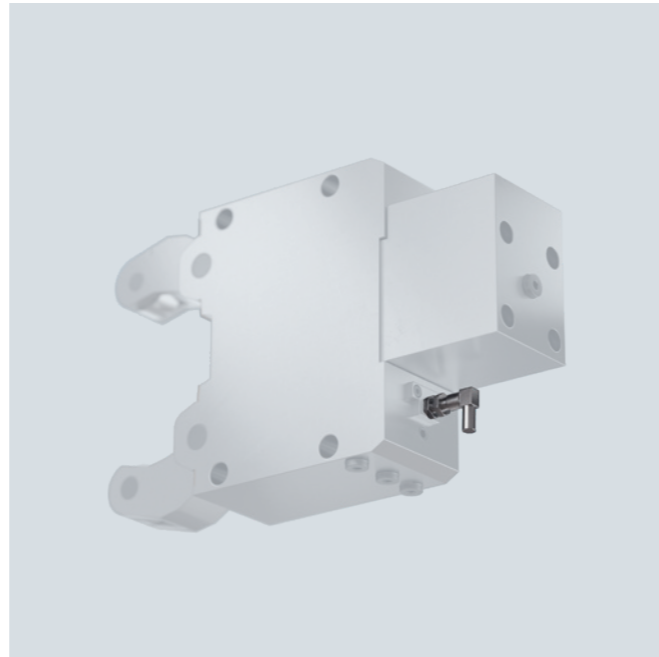

Optional sensor for customer-specific proximity switches for registering the open position (not included in the scope of delivery)

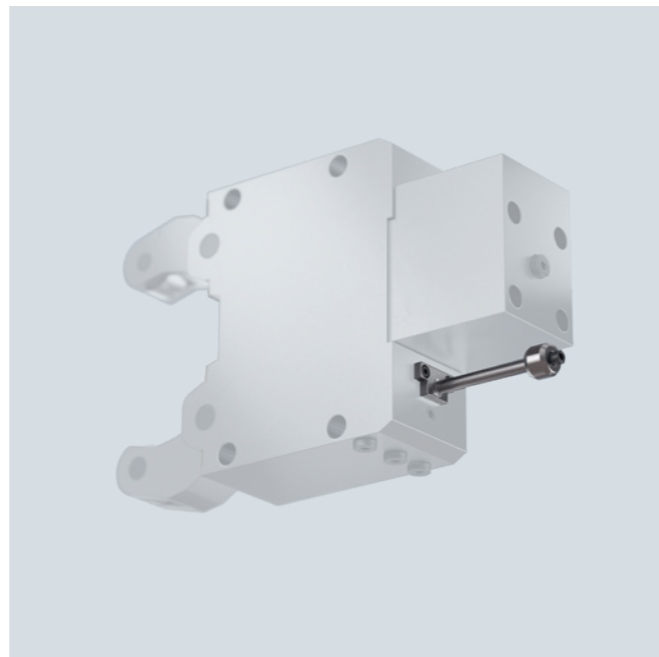

If you would like to use other position indicators or systems than the F90, the flexible Lunis modular system makes this possible.

Important for the smallest size 04-70: The optional travel measuring system is only available when preinstalled; retrofitting is not possible due to the small design.

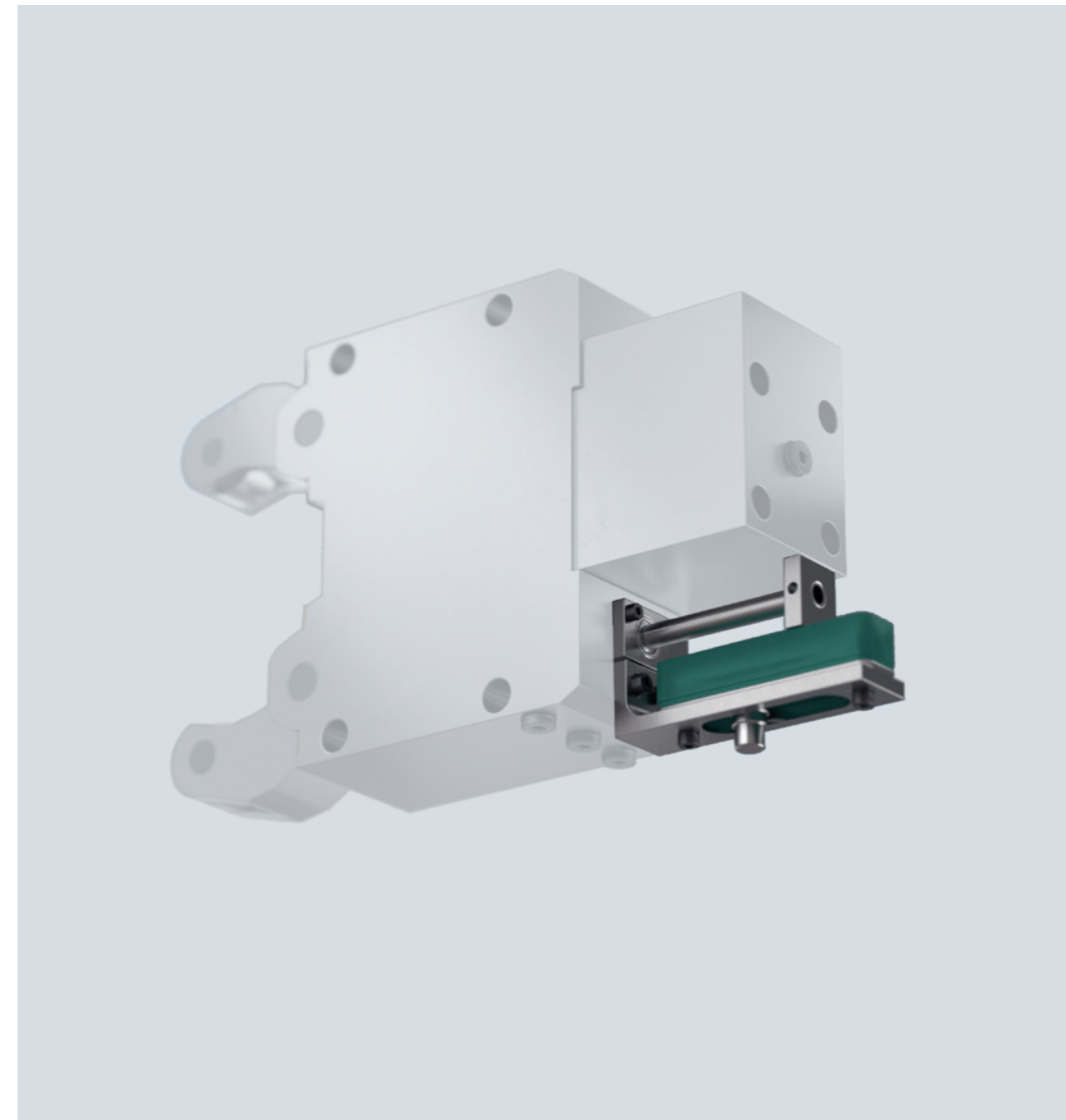

The F90 position indicating system is for the exact determination of the position of the clamping arms. It is attached to the outside of the Lunis and picks up the position of the encoder. (IO link sensors on request)

THREE CLASSIC ROUTINES

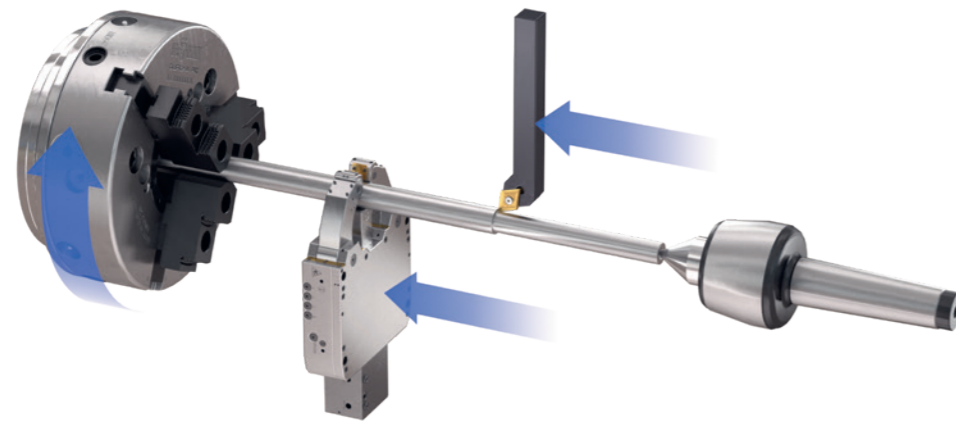

Traveling support

For the production of very precise geometries with minimal concentricity and/or form tolerances, long, slim parts are additionally supported. Such workpieces could be unintentionally deformed by the cutting forces during machining.

The steady rest absorbs these cutting forces and prevents deformation of the component. To ensure that the support is provided as for example as possible at the point of the cutting forces, the steady rest travels along with the machining tool on a steady rest carriage.

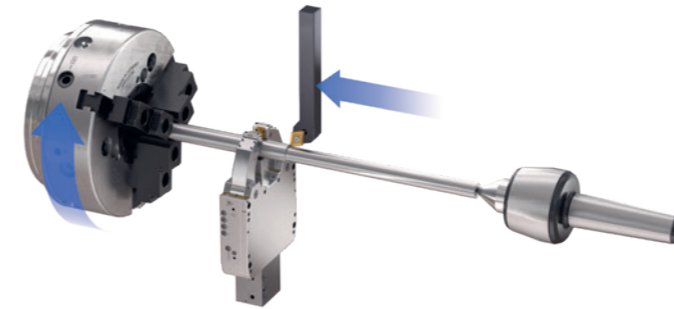

Fixed support

If your machine tool does not have a steady rest carriage, the steady rest can also be used stationary—in this case as additional, fixed support. However, since the distance of the machining tool changes towards the steady rest during machining, the cutting forces cannot be absorbed evenly. Deformation of the workpiece can not usually be completely prevented with the fixed support. It is, however, much reduced by using a steady rest than without.



Machining on the face

Steady rests are also used when it is not possible to support projecting workpieces on the opposite side by means of a live center, for example because the end face has to be machined. Then, the steady rest takes over the support at the end of the workpiece, and the end face is freely accessible. In this case, the steady rest carriage is not moved. This type of clamping can also be helpful before the actual machining in order to set the centering hole for the center.

INSTALLATION

JUST 4 SCREWS FOR THE PERFECT 10

Install the Lunis with just four screws

Steady rests—whether travelling or fixed—absorb the cutting forces during machining and improve the result. Machine tools are equipped with a separate steady rest carriage. The Lunis steady rests are attached to it with four screws and aligned with the workpiece to be machined. Appropriate connections are provided for the connection of hydraulics (G1/4", or G3/8" from 30-250), central lubrication (G1/8"), cooling water (G1/8", or G1/4" from 11-152) and compressed air (G1/8").

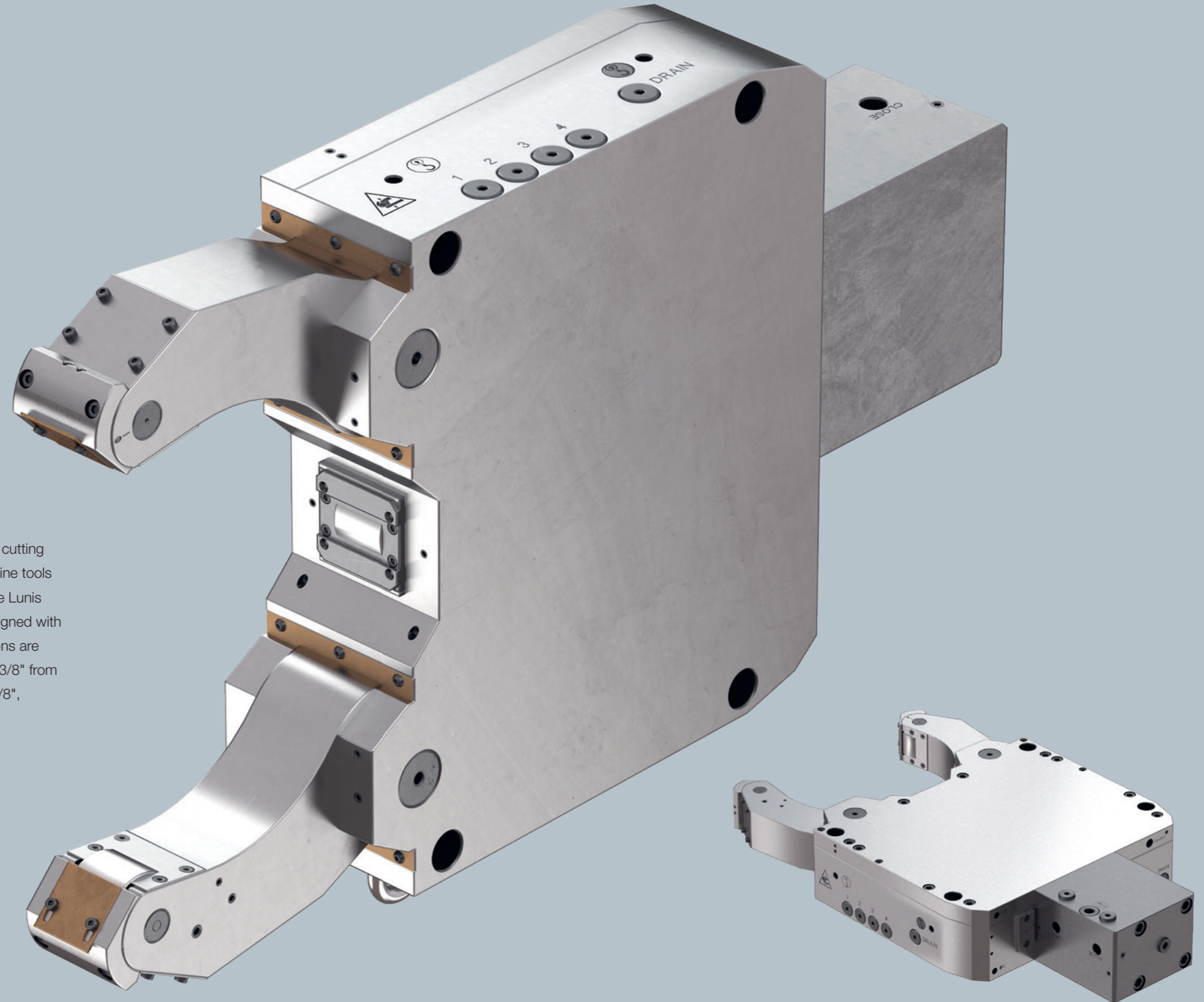

TECHNOLOGY

THE PERFECT INTERPLAY

The design of the Lunis

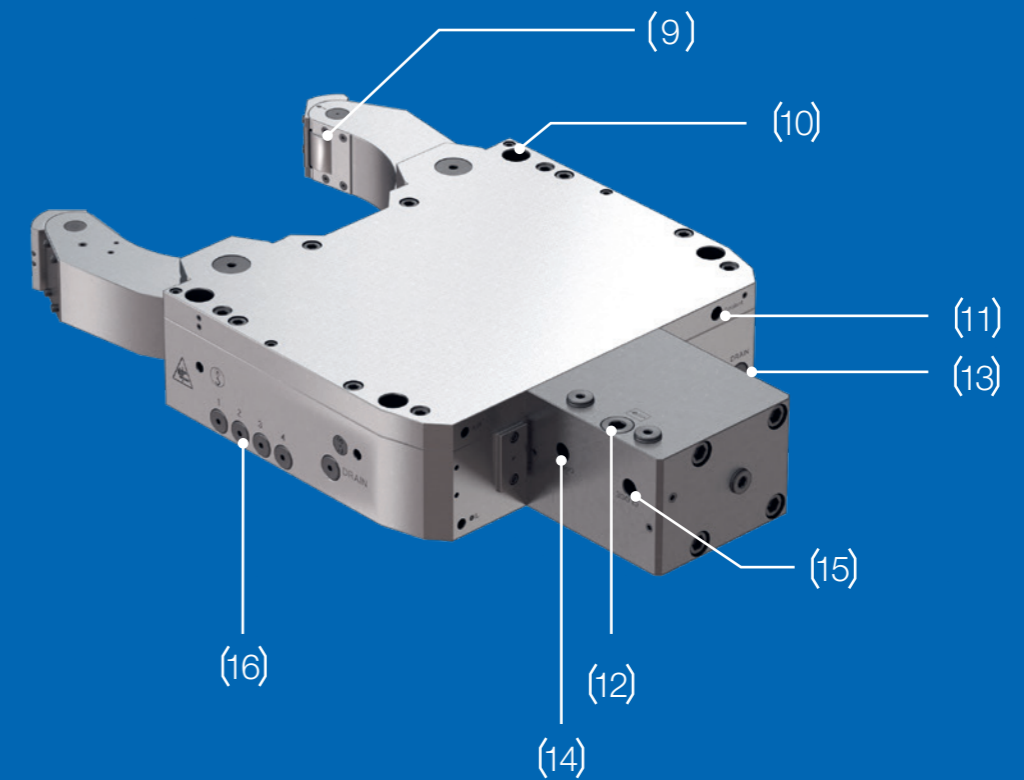
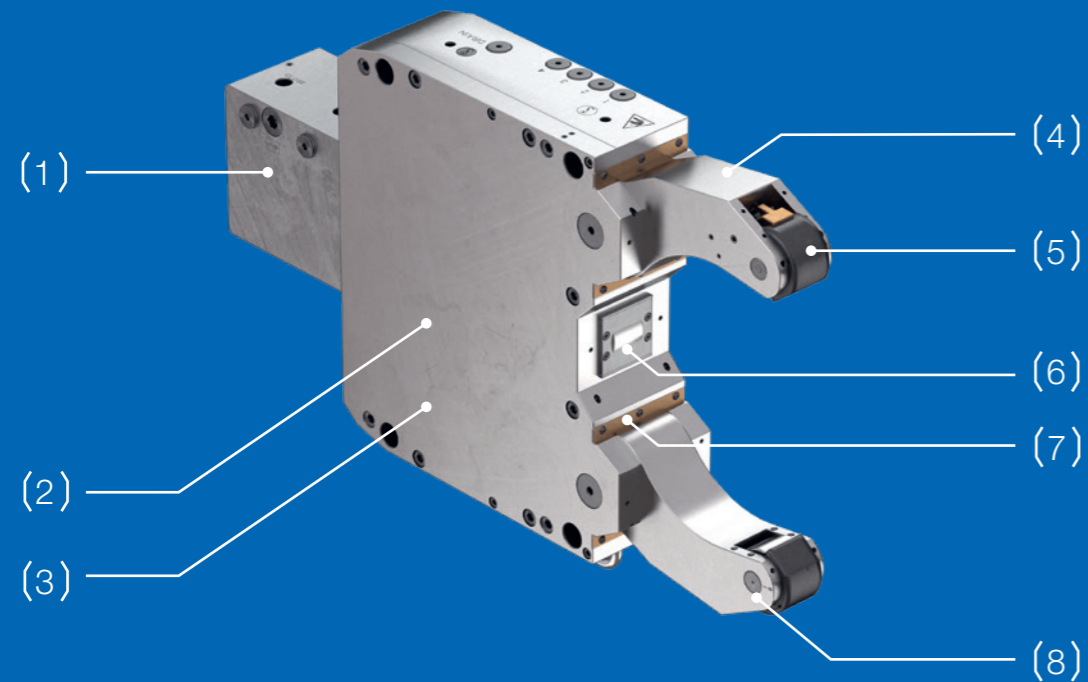

- | | |
|-----------------------------------|--|
| (1) Piston (inside) | (9) Rollers |
| (2) Cam segment (inside) | (10) Mounting holes |
| (3) Return lever (inside) | (11) Compressed air connection G1/8" |
| (4) Clamping arm, outside | (12) Safety valve |
| (5) Optional chip guard | (13) Connection for central lubrication |
| (6) Clamping arm, center | (14) Hydraulic connection (opening) |
| (7) Scraper bar | (15) Hydraulic connection (closing) |
| (8) Optional eccentric adjustment | (16) Metering cartridges (with manual lubrication option, grease nipple) |

You can find more information on the Lunis on our website:

ROEHM.BIZ/LUNIS

TECHNOLOGY

IT'S ALL ABOUT THE BALANCE OF FORCES

How the Lunis works

A steady rest is an additional center support for clamping at the ends (a clamping device on the spindle side and a center on the vice side). As the steady rest is located in the middle of the machining area of the machine, its clamping arms (4) must be guided as closely as possible to the workpiece. At the same time, remove these words, it is necessary that the forces of the side clamping arms as well as the central clamping arm (6) act exactly on the axis of rotation of the workpiece. That way, the clamping forces cancel each other out in the central point, and the workpiece is exactly centered. Ideally, the clamping forces are equal and offset by 120° to each other.



$$F_{\text{Clamping arm, left}} + F_{\text{clamping arm, right}} + F_{\text{clamping arm, center}} = 0$$

Correctly clamped, the clamping forces of the steady rest arms cancel each other out in the center of the workpiece.

The steady rest side arms swing and their points of contact with the workpiece move on a circular path and will vary depending on the workpiece diameter. Different workpiece diameters therefore require a realignment of the steady rest. The center steady rest arm moves linearly and therefore always acts on the center of the workpiece.

The side steady rest arms move on a circular path during adjustment. To ensure that the contact point of the rollers with the workpiece contour is on the direction of force, the steady rest must be adjusted to match the diameter in question.

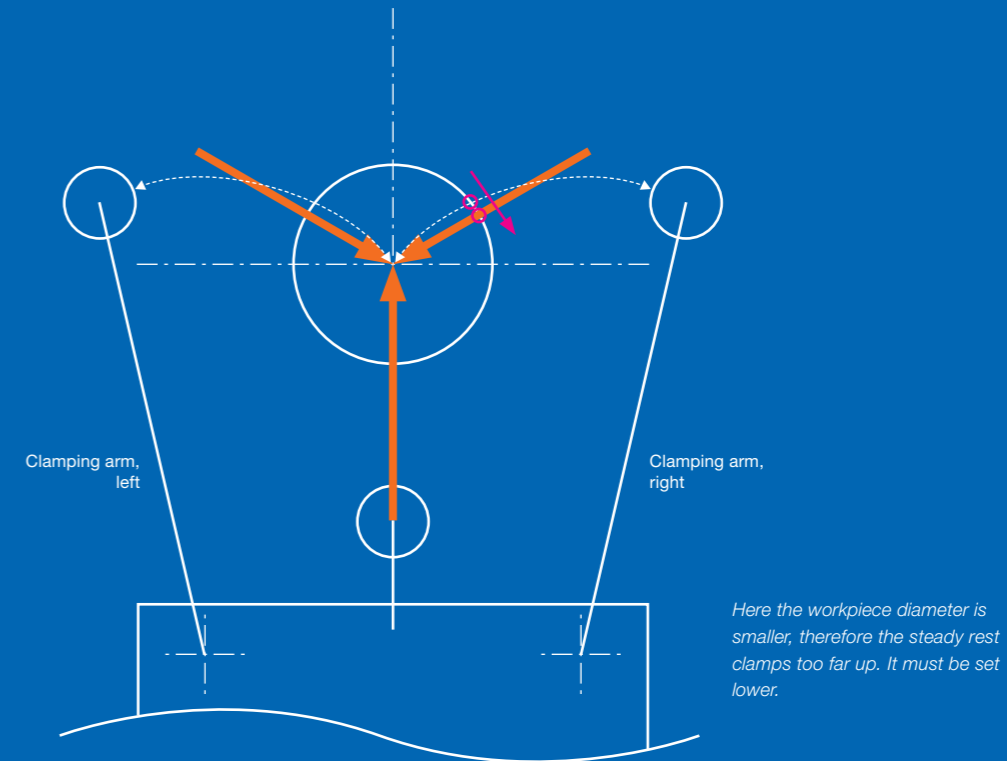

Here the workpiece diameter is smaller, therefore the steady rest clamps too far up. It must be set lower.

The side steady rest arms, as well as the middle steady rest arm, are connected inside via a control contour with the left and right return levers (3). When the cylinder is pressurised via the hydraulic supply (closing) (15), the piston (1) moves the return lever and the steady rest closes. When the hydraulic inlet (opening) (16) is pressurised, the piston of the cylinder pulls back the return lever, and the steady rest opens.

For fine adjustment of the steady rest (see above: alignment of the roller rotation center line via the outer tension rollers for exact concentricity) there is the optional eccentric adjustment (9). This can be used to adjust the rotation axis of the rollers (8).

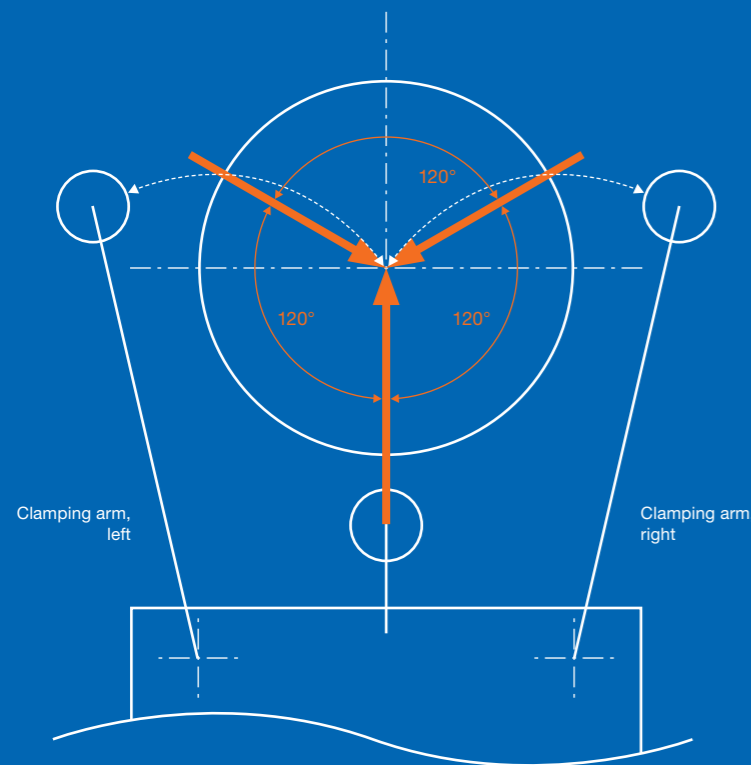

THE LUNIS IN NUMBERS

Dimensions and order numbers



VERSIONS WITH REAR-MOUNTED HYDRAULIC CYLINDER

	Coolant feed-through	Chip guard	Rollers	Eccentric fine adjustment	Proximity switch (in open position)	F90 position indicator		04-70	06-75	08-105	11-152	15-170	40-200	30-250	50-315	85-350	125-460
Min. diameter								4	6	8	11	15	40	30	30	85	125
Max. diameter								70	75	105	152	170	200	250	315	350	460
Length (dimension A)								206	214	277	428	436	455	603	696,5	716,5	953,5
Width (dimension K)								54	63	75	90	90	90	110	145	145	175
Height (dimension H)								132	160	190	290	290	290	400	440	440	680
Dimension C								51	52	70	115	123	138	146	178	198	215
Dimension E								60	66	85	135	135	135	240	270	270	330
Dimension F								118	140	170	262	262	262	365	400	400	610/640
Dimension G Ø								11	11	14	18	18	18	23	23	23	27
	No	No	Cylindrical	Order separately	Order separately	Order separately	Lunis-RZ	685751	1685569	----	----	----	----	----	----	----	----
	No	No	Spherical	Order separately	Order separately	Order separately	Lunis-RB	----	1685570	----	----	----	----	----	----	----	----
	No	Yes	Cylindrical	Order separately	Order separately	Order separately	Lunis-RZ-SS	685753	1685567	----	----	----	----	----	----	----	----
	No	Yes	Spherical	Order separately	Order separately	Order separately	Lunis-RB-SS	----	1685568	----	----	----	----	----	----	----	----
	No	No	Cylindrical	Order separately	Order separately	Order separately	Lunis-S-RZ	----	----	1686195	1686207	1686219	1686231	1686243	1686255	1686267	1686371
	No	No	Spherical	Order separately	Order separately	Order separately	Lunis-S-RB	----	----	1686196	1686208	1686220	1686232	1686244	1686256	1686268	1686372
	No	Yes	Cylindrical	Order separately	Order separately	Order separately	Lunis-S-RZ-SS	----	----	1686193	1686205	1686217	1686229	1686241	1686253	1686265	1686369
	No	Yes	Spherical	Order separately	Order separately	Order separately	Lunis-S-RB-SS	----	----	1686194	1686206	1686218	1686230	1686242	1686254	1686266	1686370
	Yes	Included	Cylindrical	Order separately	Order separately	Order separately	Lunis-SC-RZ	----	----	1686197	1686209	1686221	1686233	1686245	1686257	1686269	1686373
	Yes	Included	Spherical	Order separately	Order separately	Order separately	Lunis-SC-RB	----	----	1686198	1686210	1686222	1686234	1686246	1686258	1686270	1686374

OPTIONS

	All variants	All variants	Cylindrical	Yes	-	-		----	----	1837851	1837921	1837921	1837921	1837829	1837804	1837804	1838302
	All variants	All variants	Spherical	Yes	-	-		----	----	1837853	1837922	1837922	1837922	1837828	1837806	1837806	1838301
	All variants	All variants	independent	-	Yes	-		----	1838056	1838057	1838058	1838058	1838058	1838059	1838060	1838060	1838060
	All variants	All variants	independent	-	-	Yes		----	1838338	1838341	1838344	1838344	1838344	1838353	1838356	1838359	1838362

ACCESSORIES: CONNECTION CABLE FOR STROKE MONITORING

Proximity switch F90 position indicator

Angled plug, 5 m	792178	1145115
Straight plug, 5 m	876342	1008090

INFORMATION ON ORDERING:

The options eccentric fine adjustment, position indicator F90, and proximity switch must each be ordered in addition to the Lunis. This means that you must order an additional item number for each option.

* Data without chip protection

THE LUNIS-B IN NUMBERS

Dimensions and order numbers



VERSIONS WITH SIDE-MOUNTED HYDRAULIC CYLINDER

	Coolant feed-through	Chip guard	Rollers	Eccentric fine adjustment	Proximity switch (in open position)	F90 position indicator		08-105	11-152	15-170	40-200	30-250	50-315	85-350	125-460
Min. diameter								8	11	15	40	30	30	85	125
Max. diameter								105	152	170	200	250	315	350	460
Length (dimension A)								228	341	349	368	483,5	574	594	780
Width (dimension K)								75	90	90	90	110	145	145	175
Height (dimension H)								62	100	100	100	119	114	114	185
Dimension C								190	290	290	290	400	440	440	680
Dimension E								70	115	123	138	146	178	198	215
Dimension F								85	135	135	135	240	270	270	330
Dimension G Ø								170	262	262	262	365	400	400	610/640
Maß G Ø								14	18	18	18	23	23	23	27
	No	No	Cylindrical	Order separately	Order separately	-	Lunis-B-S-RZ	1686201	1686213	1686225	1686237	1686249	1686261	1686273	1686377
	No	No	Spherical	Order separately	Order separately	-	Lunis-B-S-RB	1686202	1686214	1686226	1686238	1686250	1686262	1686274	1686378
	No	Yes	Cylindrical	Order separately	Order separately	-	Lunis-B-S-RZ-SS	1686199	1686211	1686223	1686235	1686247	1686259	1686271	1686375
	No	Yes	Spherical	Order separately	Order separately	-	Lunis-B-S-RB-SS	1686200	1686212	1686224	1686236	1686248	1686260	1686272	1686376
	Yes	enthalten	Cylindrical	Order separately	Order separately	-	Lunis-B-SC-RZ	1686203	1686215	1686227	1686239	1686251	1686263	1686275	1686379
	Yes	enthalten	Spherical	Order separately	Order separately	-	Lunis-B-SC-RB	1686204	1686216	1686228	1686240	1686252	1686264	1686276	1686380

OPTIONEN

	All variants	All variants	Cylindrical	Yes	-	-		1837851	1837921	1837921	1837921	1837829	1837804	1837804	1838302
	All variants	All variants	Spherical	Yes	-	-		1837853	1837922	1837922	1837922	1837828	1837806	1837806	1838301
	All variants	All variants	independent	-	Yes	-		1838057	1838058	1838058	1838058	1838059	1838060	1838060	1838060

ACCESSORIES: CONNECTION CABLE FOR STROKE MONITORING

Proximity switch F90 position indicator

Angled plug, 5 m	792178	-
Straight plug, 5 m	876342	-

* Data without chip protection

INFORMATION ON ORDERING:

The options eccentric fine adjustment, position indicator F90, and proximity switch must each be ordered in addition to the Lunis-B. This means that you must order an additional item number for each option.

CAD data for the Lunis can be found at

www.roehm.biz/Lunis

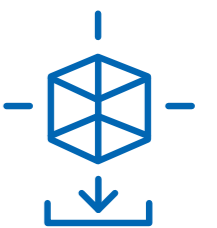

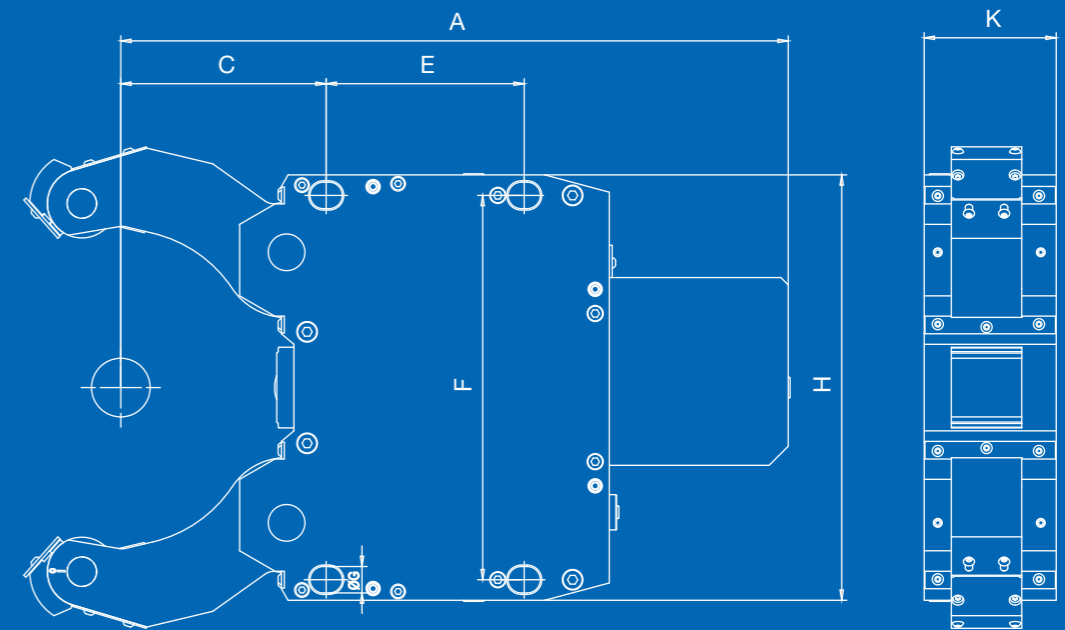
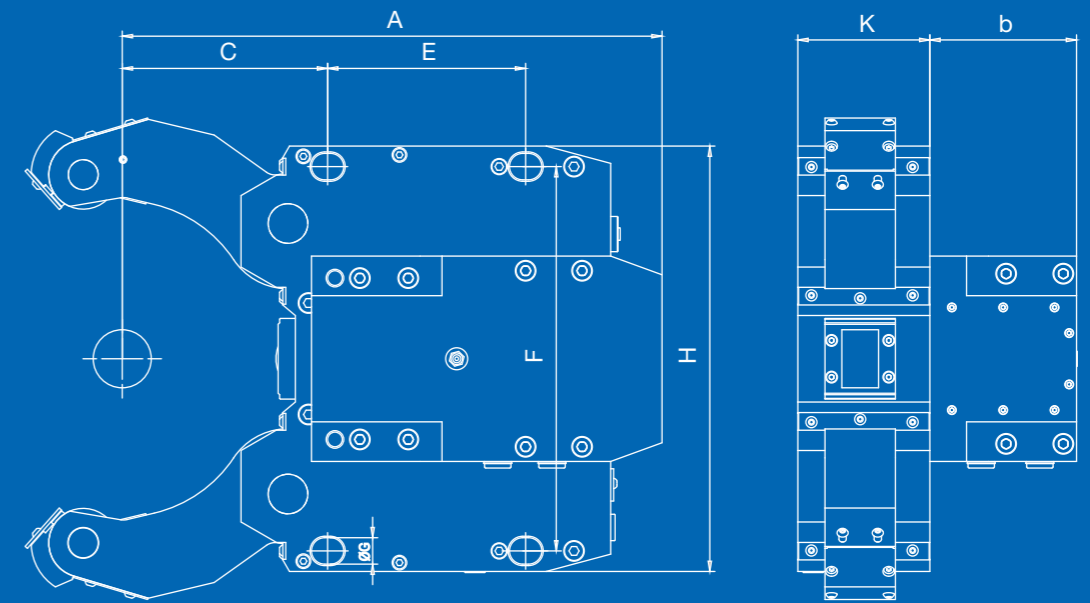
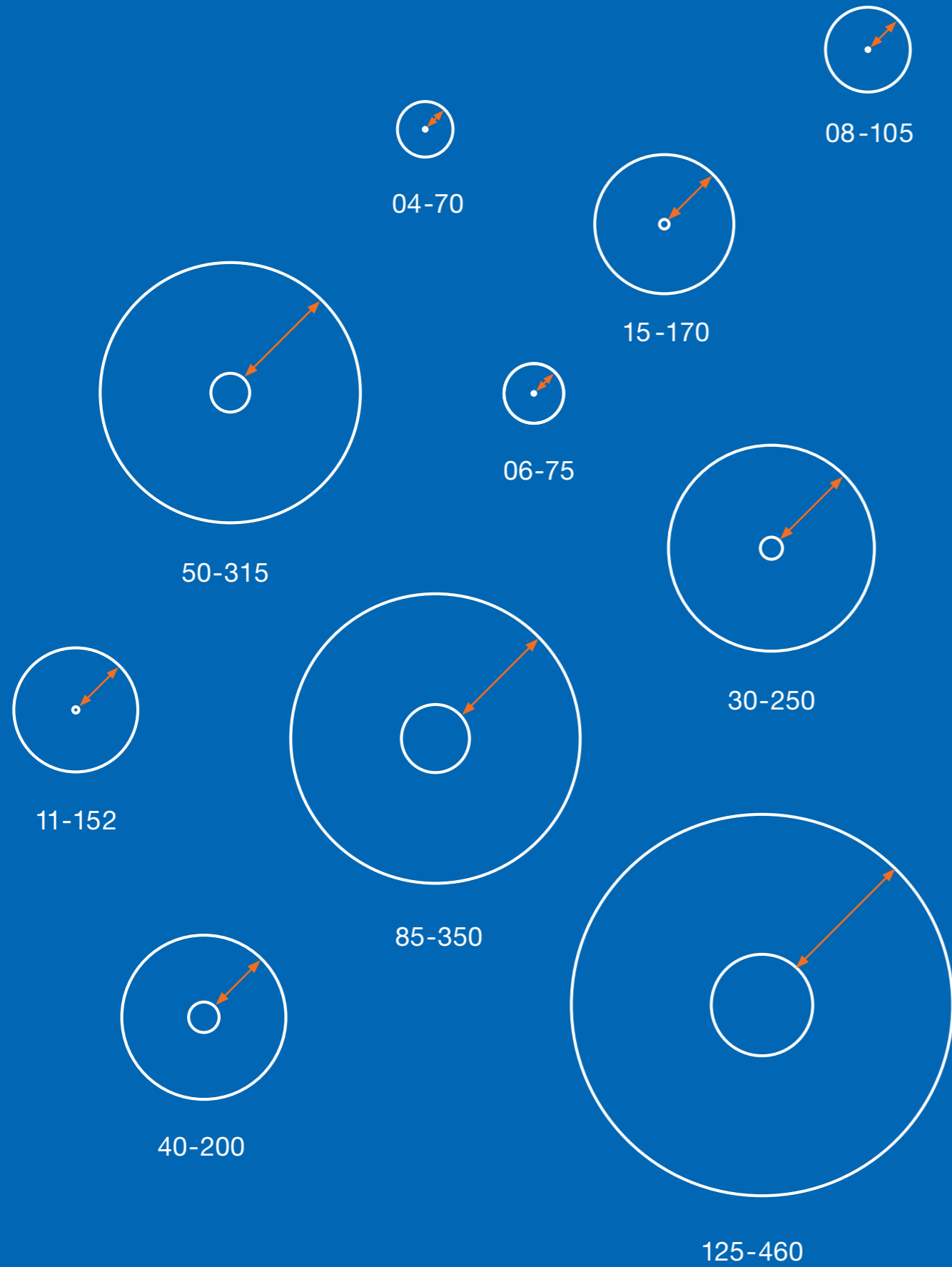

EXPLANATION



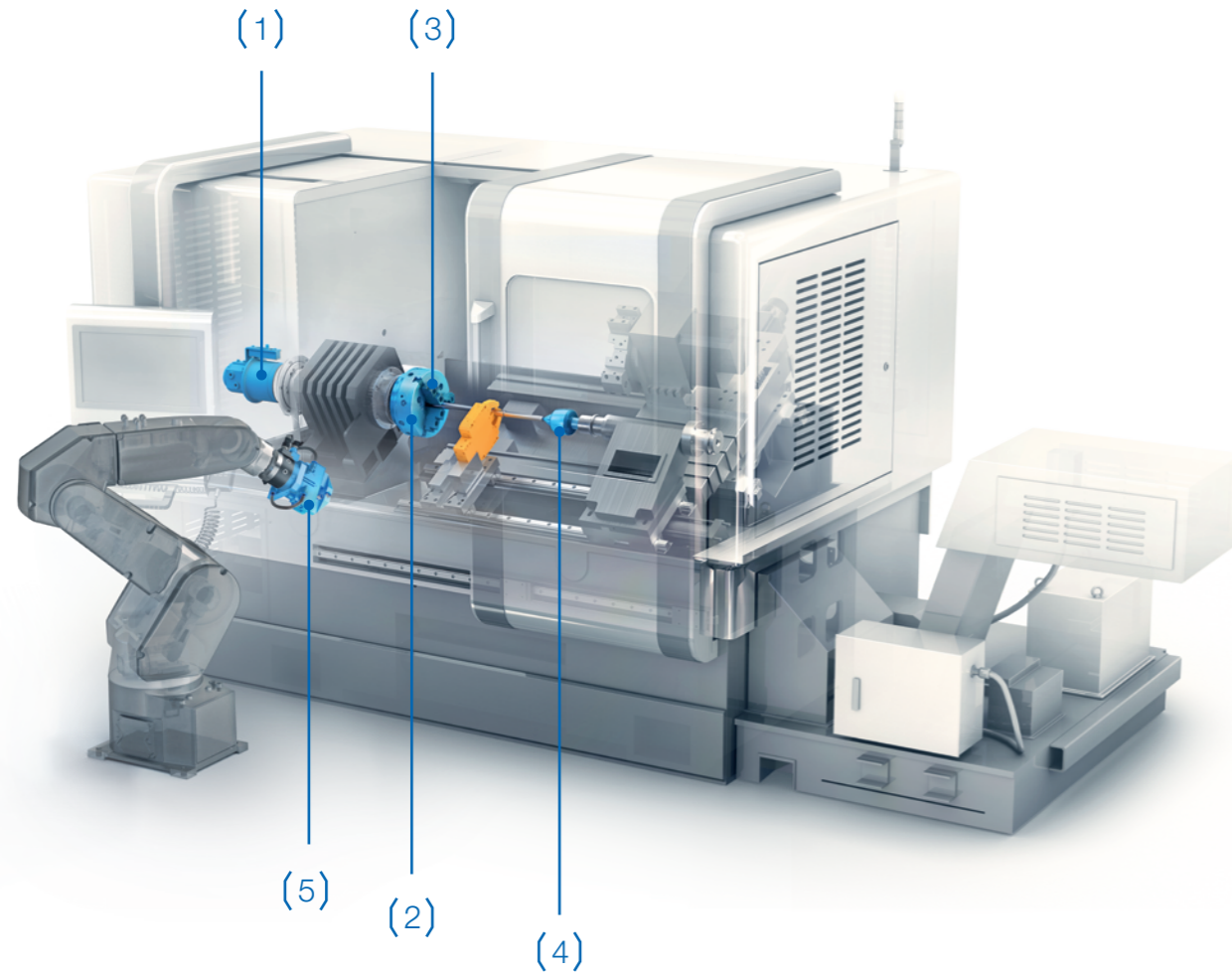

YOU NEED THE WHOLE SYSTEM ...

The steady rests of the Lunis series are an essential element for clamping on your machine tool. But precise clamping requires even more components. We have the complete system for this.



(1)  ... to automatically clamp power chucks. Röhmlunis offers hydraulic clamping cylinders with and without through-holes for this.

(2)  ... to be able to clamp at all. Röhmlunis has matching, force-actuated clamping devices for this.

(3)  ... to clamp workpieces correctly. Röhmlunis offers an extensive range of top jaws for this.

(4)  ... to center long turned parts on the opposite side. There are live centers from Röhmlunis for this.

(5)  ... for automated manufacturing. Röhmlunis also offers an extensive selection of grippers and swiveling devices for assembly and loading robots.



You can conveniently buy clamping and gripping technology from Röhmlunis in our online shop 24/7

eshop247.roehmlunis.biz

PRACTICAL TIP

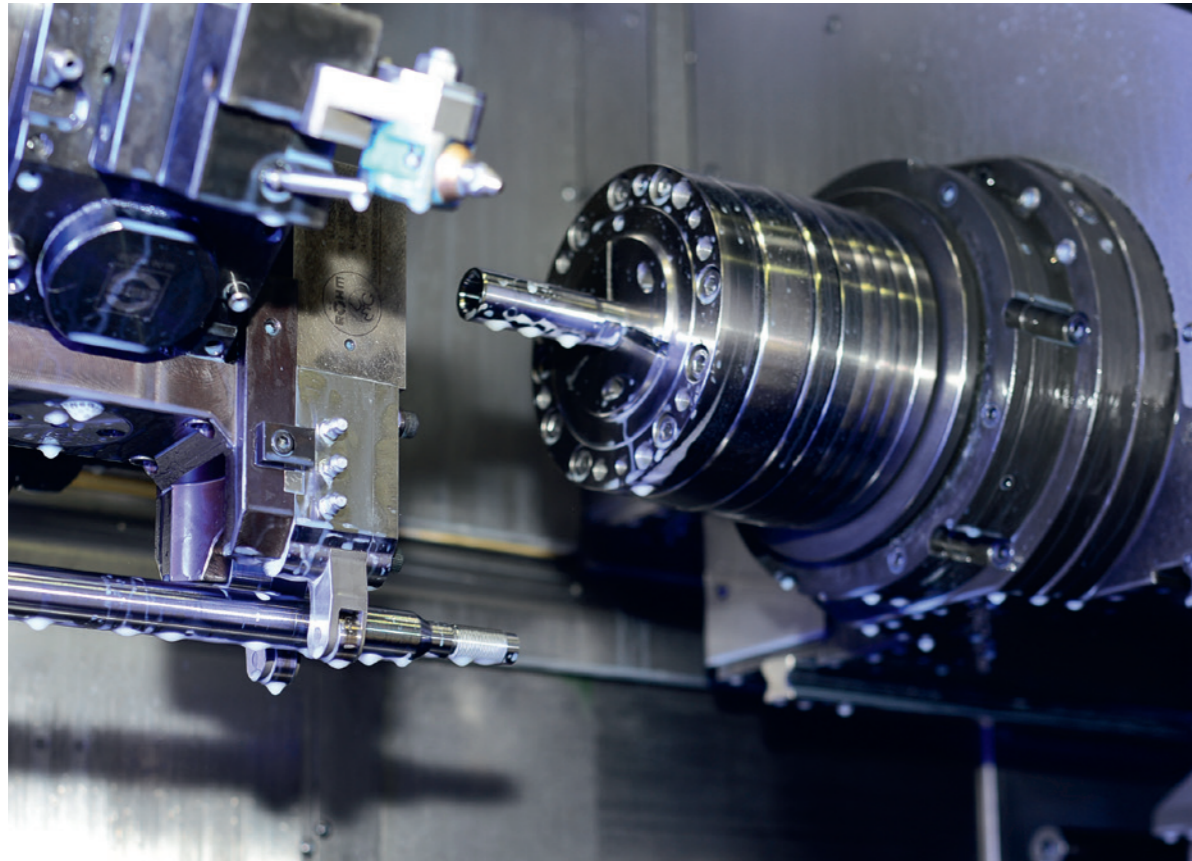

THE TURRET STEADY REST

An example of best practice engineering at Röhmi

Do you have a specific project requirement that isn't covered by the wide Lunis range? Röhmi can help you with that too.

We are known worldwide for our customized solutions for a wide range of industries. This ranges from minor modification of a standard product right up to a complete redesign of an integrated clamping system.

On the page opposite, we would like to present a project concerning the special connection for a steady rest steady rest as an example.

"A steady rest has to be installed on the machine!"

Wesa GmbH in Waldstetten specializes in CNC complete machining. As a pure service provider, the company focuses on metal processing and employs around 50 people. Typical orders include the production of ready-to-install pinions and gear shafts.

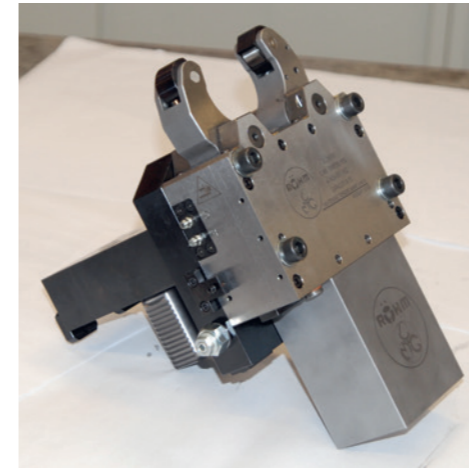

Jointly developed by Röhmi and Wesa:
Turret steady rest for machines without the option to attach a standard steady rest.

Wesa's machine portfolio has long included a CNC turning machine for manufacturing long, thin components. These are workpieces that are usually supported with a steady rest to be able to machine them with high precision.

Originally, no steady rest was provided in the turning center of the CNC turning machine. There was no hydraulic connection on the machine. And the turret also dictated the installation interfaces: a standardized VDI shaft for holding the steady rest and a connection hole for the coolant. The framework conditions of the order for Röhmi were clearly defined: a small tool turret, limited working space and no hydraulic connection.

The Wesa production manager said at the time: „Those are the specifications! A steady rest has to be installed on the machine! Get on with it! And 18 to 36 mm had to be adhered to as the clamping range.

How do you control a steady rest without a hydraulic connection?

It is common for a standard tool turret to have two oil hydraulic connections. But, because Wesa did not want to install another medium in the machine, the idea matured to use the coolant and the existing line for this purpose to trigger the control commands: The steady rest is closed by coolant pressure and opened again by spring force.

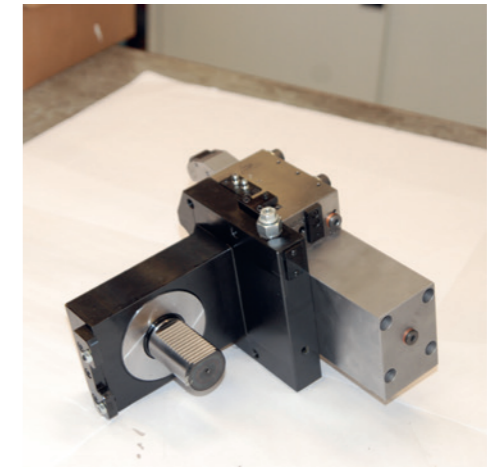

Steady rest in the turret of the turning machine.

The solution on the machine: The CNC controller moves the open steady rest to position, followed by the signal "coolant on". The clamping arms of the steady rest close and the workpiece is now securely supported and ready for the next machining step. The return spring force then opens the clamping arms of the steady rest again.

A HELPING HAND FOR YOUR MACHINE TOOL

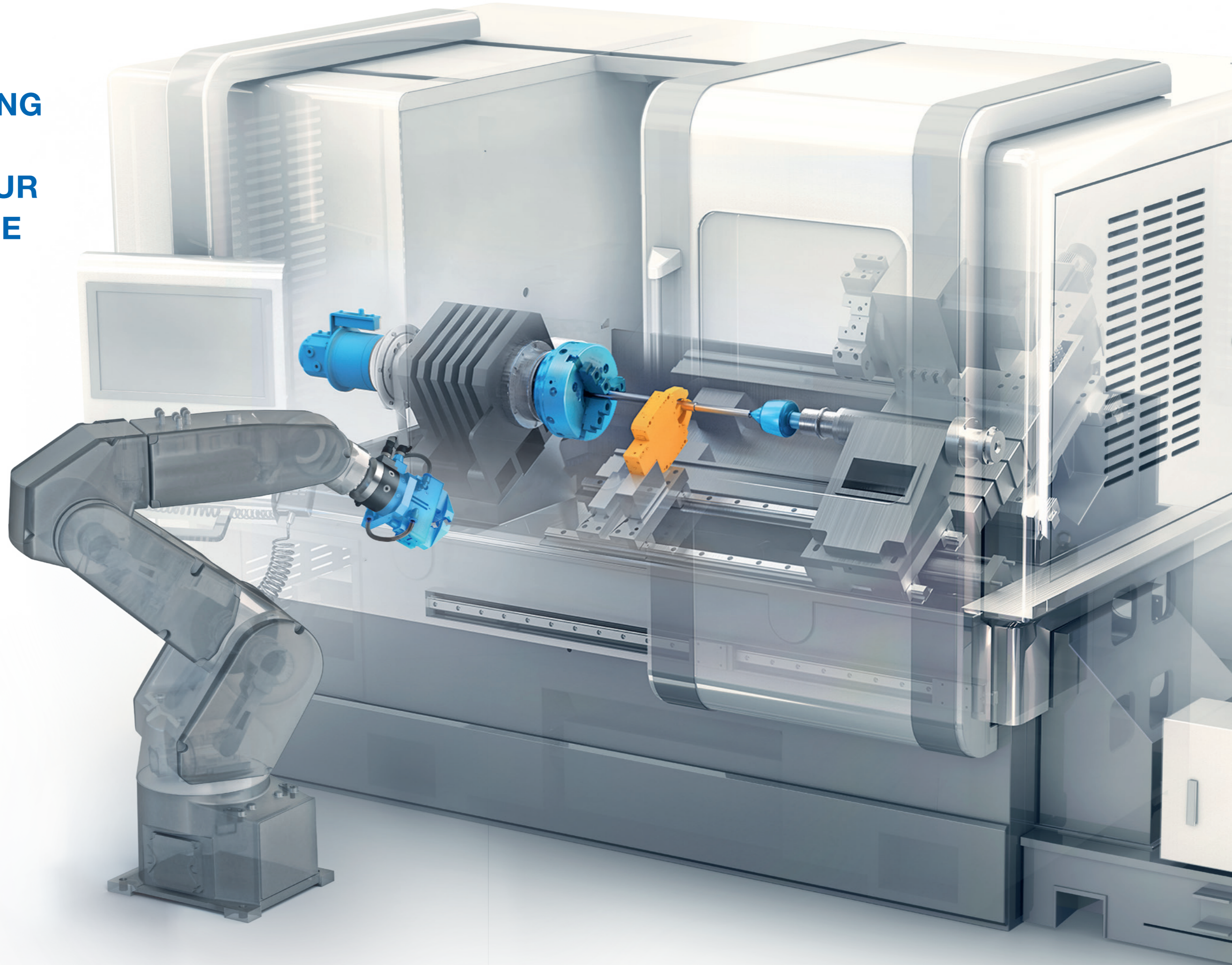



RÖHM Products of America, Inc. • 2500 Northlake Drive, Suwanee • GA 30024 • USA
TEL 001 770 963 84 40 • sales@rohms-products.com • roehm.biz